



Take Today, Add Tomorrow

Worldwide References of IEX Series Industrial Ethernet Extenders

Extending Ethernet over Existing Copper Wires

Today's networks have larger bandwidth and faster speed requirements. This is because more and more devices and applications, such as video surveillance, are connected and converged on one network for centralized analysis and management to achieve higher efficiency and increase safety. This trend, known as the Industrial Internet of Things (IIoT), has driven businesses to upgrade their existing networks to cope with these new requirements.

As an alternative to investing in new cables for system upgrades, Moxa's IEX Ethernet extenders provide users with greater flexibility for linking devices together over long distances using existing copper wiring. When costs need to be reduced, users can easily take the legacy system, and transform it into a modern network, while saving time and money. Read on to learn more details about worldwide user cases.

Easy Installation

Auto CO/CPE negotiation

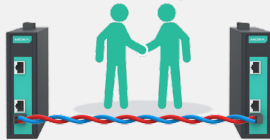

The IEX series has an automatic CO/CPE negotiation function that enables plug-n-play, and is configuration-free for easy deployment.

High Reliability

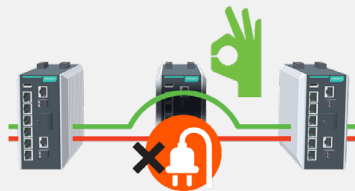







The IEX series supports Turbo Ring and Turbo Chain redundancy protocols for millisecond-level recovery as well as the bypass function for multiport failure tolerance.

Easy Management



The IEX series supports LED indicators for easy on-site troubleshooting. Users can also remotely manage the connection status via MXview network management software.

Selection Guide

	IEX-402-SHDSL	IEX-402-VDDSL2	IEX-408E-2VDDSL2
Model	  Datasheet	  Datasheet	  Datasheet
RJ45 Port	1 x 10/100M	1 x 10/100M	6 x 10/100M
DSL Port	1	1	2
Redundancy	Link Fault Pass-Through (LFP)	Link Fault Pass-Through (LFP)	<ul style="list-style-type: none"> • Turbo Ring, Turbo Chain fast redundancy • DSL bypass
Operating Temperature	-10 to 60°C or -40 to 75°C (T models)		
Power Supply	LV: 12/24/48 VDC (9.6 to 60 VDC)		LV: 12/24/48 VDC (9.6 to 60 VDC), HV: 110/220 VDC/VAC (88 to 300 VDC, 85 to 264 VAC)
Approvals	CE/FCC, UL 508, EN 50121-4, SafetyNET p	CE/FCC, UL 508, EN 50121-4, NEMA TS2, ATEX/C1D2	CE/FCC, UL 61010, EN 50121-4, NEMA TS2, ATEX/C1D2, IEC 61850-3

Intelligent Transportation System

Location: U.S.A.

Secure Traffic Signal Control and CCTV Monitoring in a Harbor

When the monitoring system along a key harbor corridor in a major American city needed updating, the system manager decided to use existing copper wiring to transmit data over significantly longer distances. As this project needed to integrate more systems into one network, serial networks were no longer sufficient to support the expanded network, which is why an industrial Ethernet technology over copper wires via a DSL was required to support more bandwidth over longer distances. In addition, VPN connections and firewall protection were required to ensure network safety and data integrity.

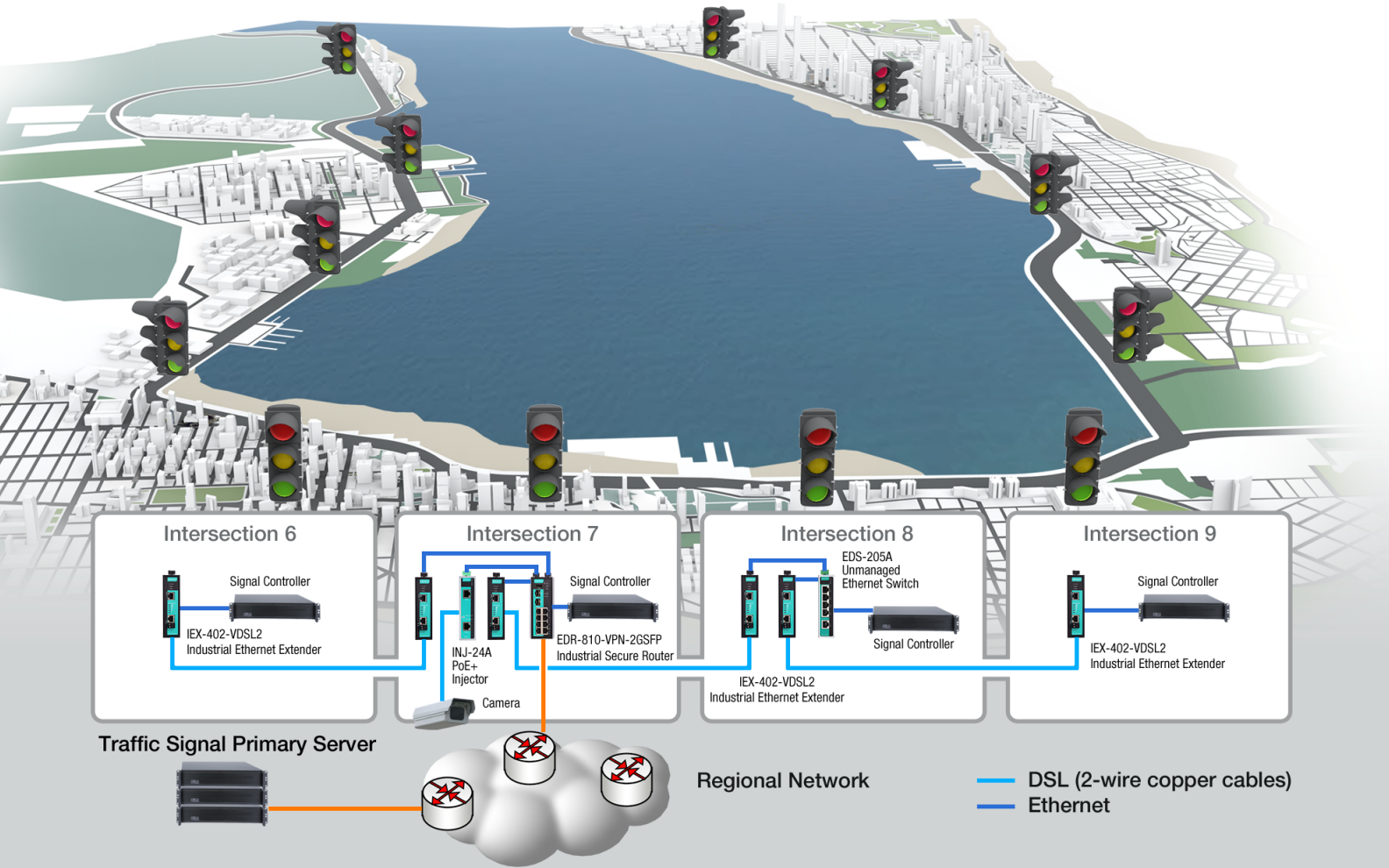

System Requirements

- Use existing copper wires to carry data over several kilometers, using DSL technology
- VPN connection and firewall protection to secure remote access and protect signal control and video data

Why Moxa?

- IEX-402 DSL extenders support easy-extension point-to-point (P2P) over long distances through existing copper wires
- Easy installation with auto CO/CPE negotiation
- EDR-810 secure routers support both VPN connections and firewall protection to protect intersection controllers and videos on the countywide Internet

Location: Australia

Building a Subsea Oil & Gas Control Application with Industry-Specific Cables

For subsea control applications, great efforts are made to install industry-specific cables under the sea. In this project, the number one requirement is to leverage the existing infrastructure to reduce costs and time spent on installing cables. In addition, oil & gas environments are extremely hazardous due to the high pressures the products are subjected to, so the installation has to be quick and must support remote management and diagnosis.

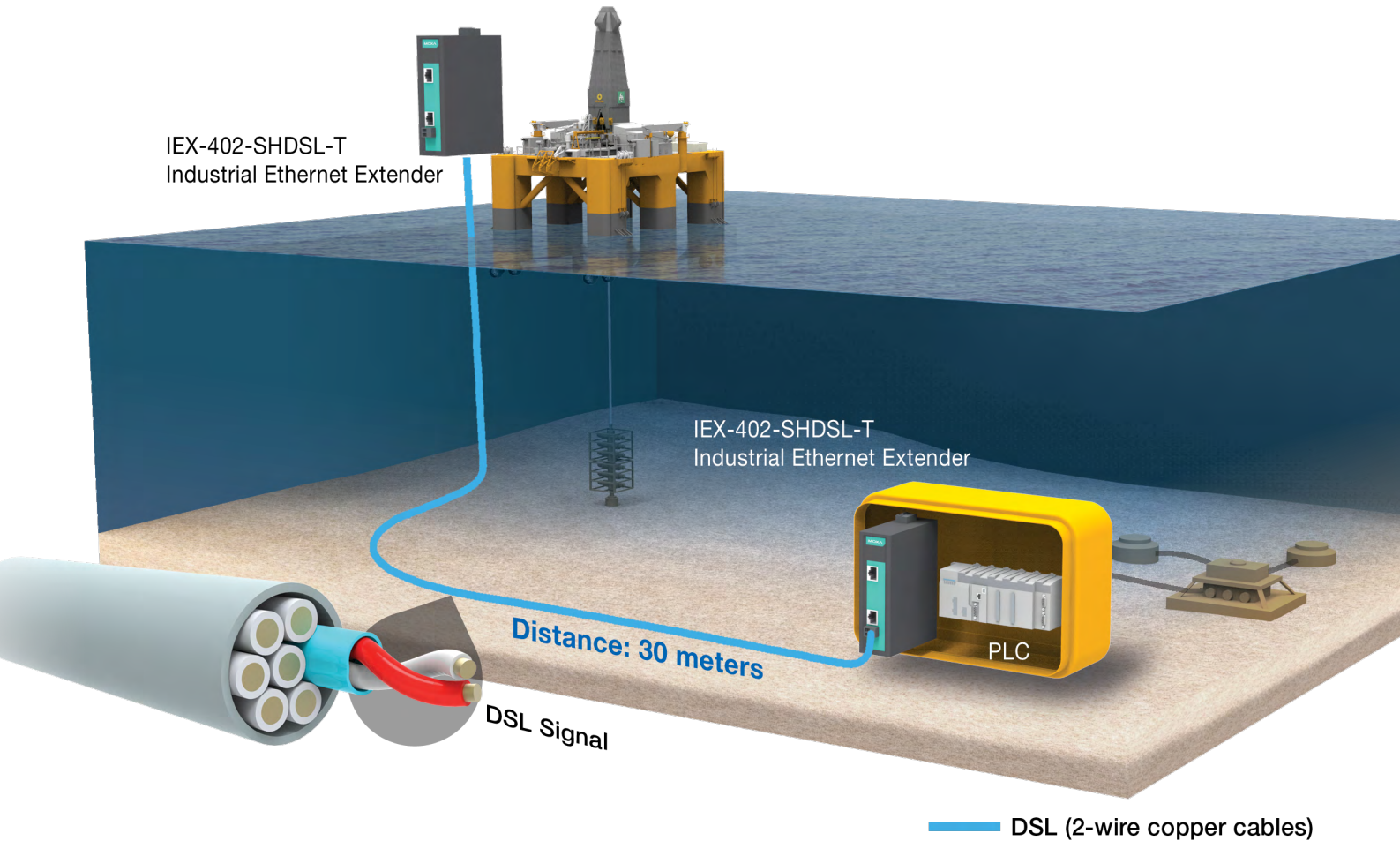

System Requirements

- Utilize existing industry-specific wires under the sea to lower the risk of damaging cables
- Easy installation, diagnosis, and management
- Reliable operation in harsh environments

Why Moxa?

- The IEX-402 allows users to extend Ethernet over existing industry-specific cables
- Easy installation with auto CO/CPE negotiation
- -40 to 75°C wide operating temperature range and rugged design for harsh environments

Location: Hong Kong

Repurposing 2-Wire Copper for an Alert System

In order to increase patient safety, a hospital in Hong Kong set up an IP-based emergency alert system, including surveillance cameras, in the bathrooms of a ward. This system must be connected to the facility's advanced emergency network. After an alarm is triggered, the staff can immediately see what is happening and respond faster if one of their patients has an emergency. Projects such as these must be completed quickly and use the existing infrastructure in order to avoid construction that would interfere with hospital operations.

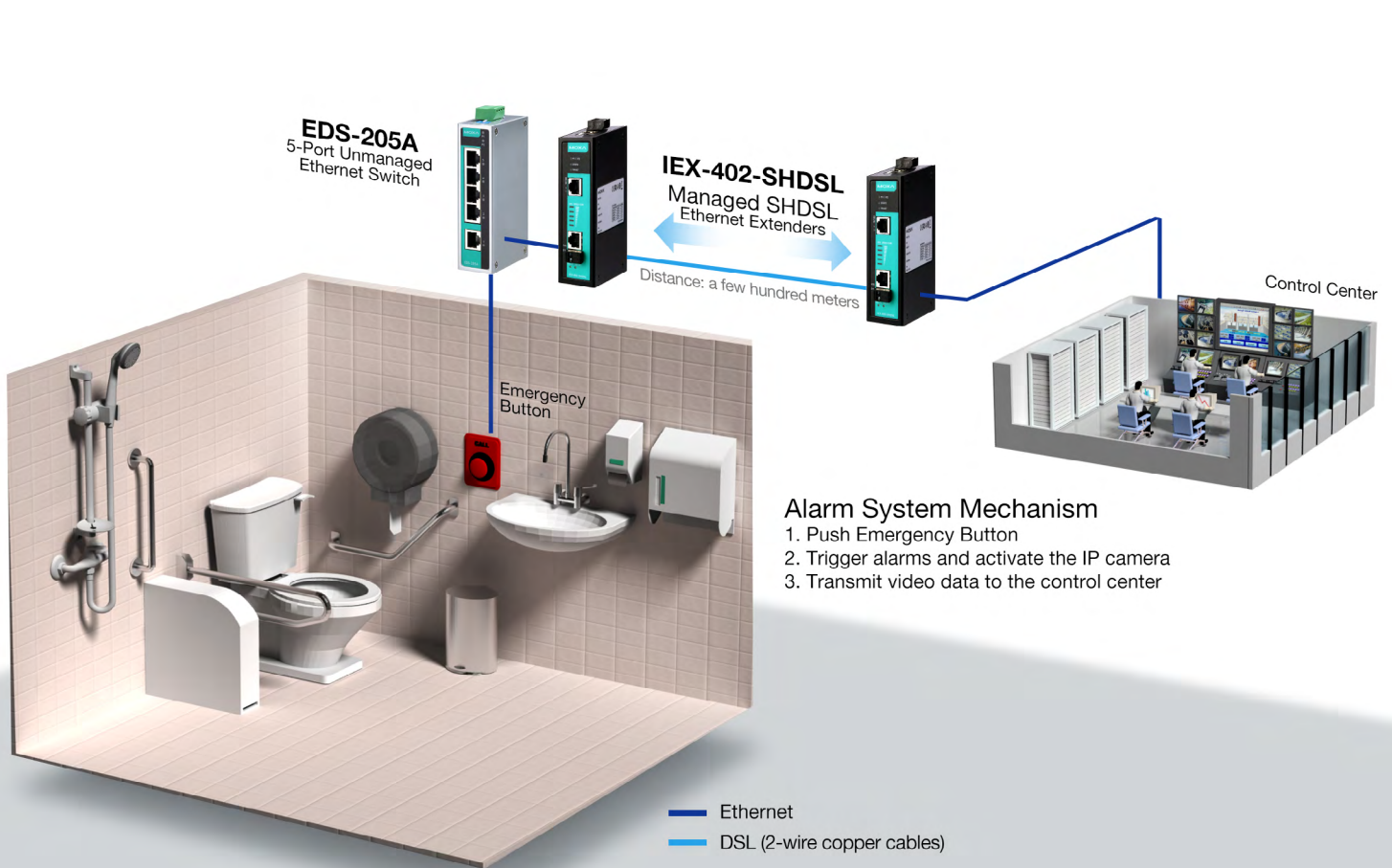

Alarm System Mechanism

1. Push Emergency Button
2. Trigger alarms and activate the IP camera
3. Transmit video data to the control center

System Requirements

- Transmit emergency alerts and video footage over distances of up to a few hundred meters without having to reconstruct the entire network infrastructure
- Data transmission over existing 2-wire copper cables
- Fast deployment in order to reduce disruption and risks to patients

Why Moxa?

- Support for long-distance point-to-point transmission over existing copper wires
- Easy installation with auto CO/CPE negotiation

Location: Europe

Robust CCTV Monitoring and Control System for an Underground Mine

A leading mine operator decided to implement a reliable remote IP-based control and monitoring system. However, as drilling sites and internal passageways increase, more and more sensors and cameras need to be deployed, so the network is constantly changing. Fiber cabling is not an ideal choice for this project because it can be easily damaged in a mine that has a lot of industrial machinery. In addition, there is a high risk of accidents being caused by cable splicing. Using the IEX-402 DSL extender allows the mining operator to build a long-distance CCTV monitoring and control system over industry-specific cables in the hazardous and constantly changing mining environment.

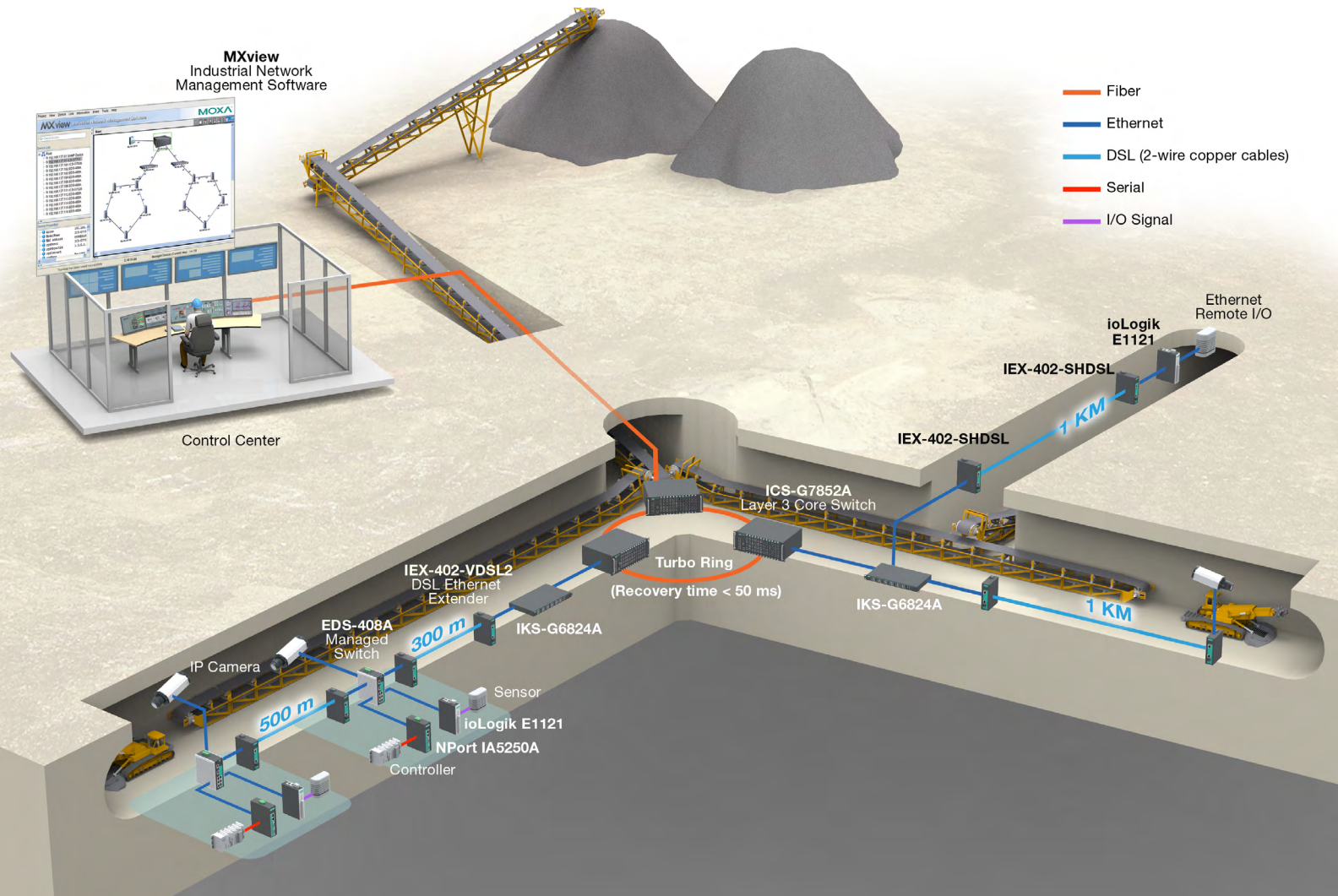

System Requirements

- Transmit control signals and video reliably over 1 km or farther in harsh conditions
- Use existing industry-specific copper wiring for high resilience and adaptability for network expansion
- Support for remote troubleshooting and maintenance

Why Moxa?

- Ethernet extension up to 3 km for VDSL2 and 8 km for G.SHDSL with high data rates
- Robust, fanless design for high system reliability in hazardous environments
- Simple troubleshooting via panel indicators and virtual panels through MXview

Intelligent Transportation System

IEX-408E Case Study

Integrated Crossroads Traffic Signal Control and CCTV Monitoring Systems

Nowadays, governments are upgrading to IP-based traffic signal systems so they can manage and monitor traffic over the Internet. In addition, governments typically want to integrate an IP-based CCTV surveillance system over the same network, which causes networks to require larger bandwidth. To reduce costs, the ideal option is to use a device that supports a DSL option, such as Moxa's IEX-408E Ethernet extender switch that can utilize existing wires between intersections and support long-distance communications as well as high bandwidth to smoothly process all the data on the network. The information collected, combined with the new and expanded network, allows control center staff to see the big picture and keep traffic running smoothly across their entire network.

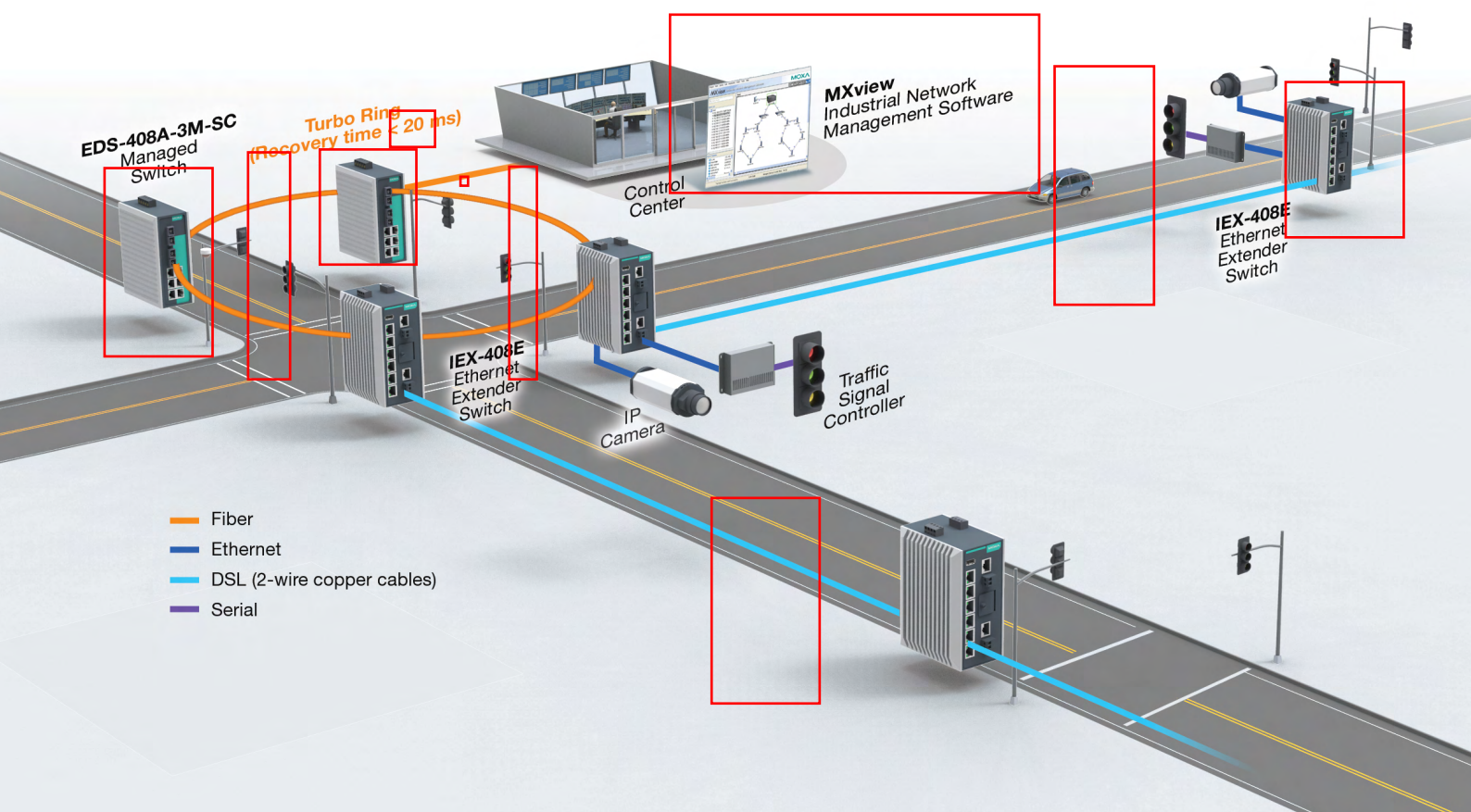

System Requirements

- Transmit control signals and video reliably over twisted-pair copper cables
- Use existing copper wiring for high resilience and adaptability for network expansion
- Support for remote troubleshooting and maintenance

Why Moxa?

- Ethernet extension up to 3 km for VDSL2 with high data rates
- Robust, fanless design for high system reliability in hazardous environments
- Simple troubleshooting via panel indicators and virtual panels through MXview

Cost-Effective Long-Distance Oil Pipeline Monitoring

Any maintenance on oil & gas pipelines is very difficult due to the location of the pipeline, which is usually deployed over hundreds of miles across harsh outdoor environments. For such projects, products that use industrial Ethernet over copper via DSL, such as Moxa's IEX-408E Ethernet extender switch, are advantageous because they can utilize copper wires to reduce the installation risks and the maintenance costs. In addition, the industrial-grade design of Moxa's Ethernet extender switches help ensure the durability required for uninterrupted network communications in oil & gas applications.

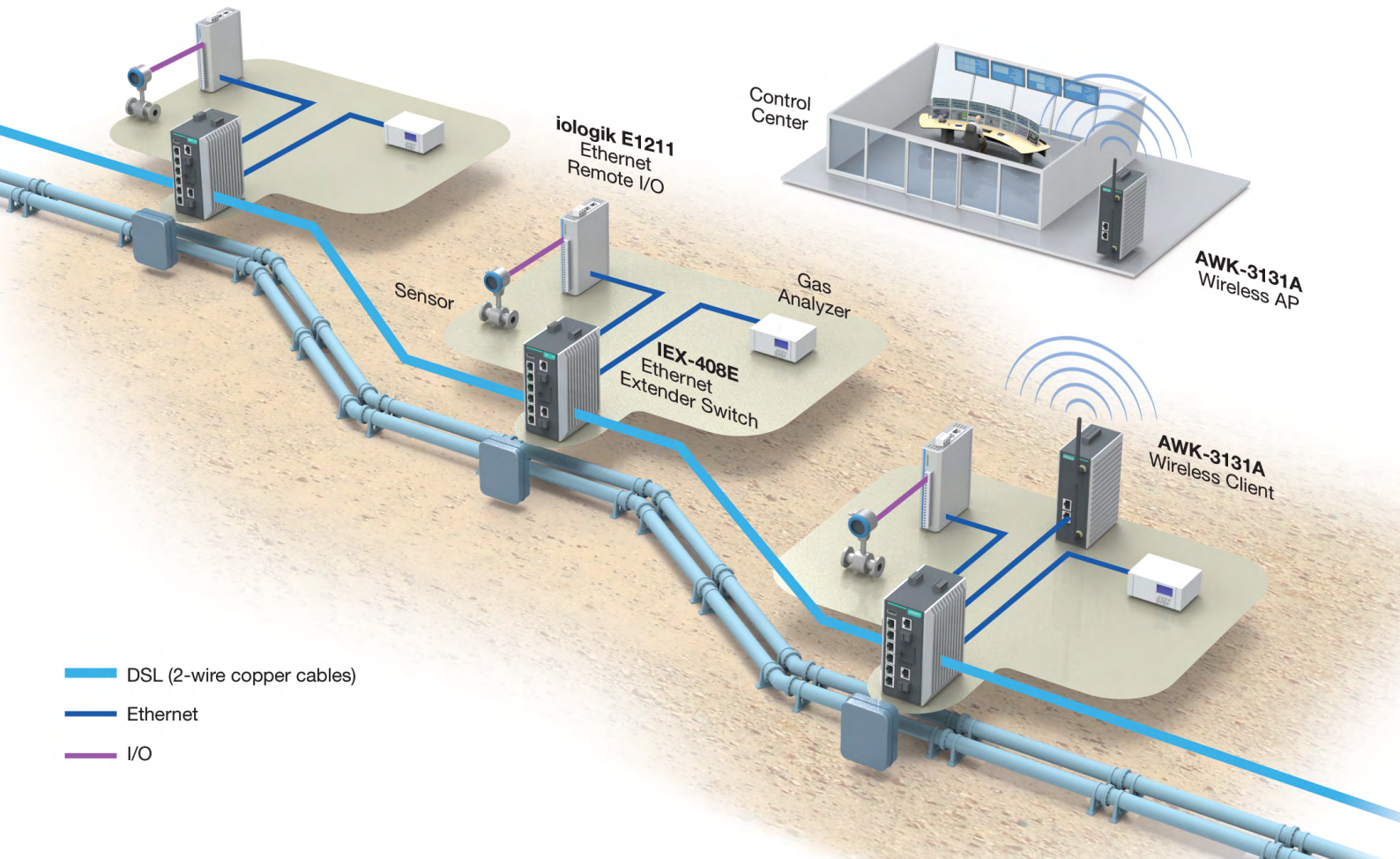

System Requirements

- Long-distance data transmission over twisted-pair copper cables
- Easy installation, diagnosis, and management
- Reliable operation in harsh environments

Why Moxa?

- Long-distance transmission up to 3 km over 2-wire copper cables
- Auto CO/CPE negotiation for easy installation
- -40 to 75°C wide operating temperature range and rugged design for harsh environments
- A DSL bypass to give multiple fault tolerance to higher network reliability in a daisy chain topology

Learn More

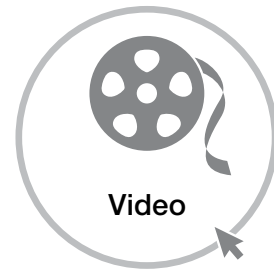
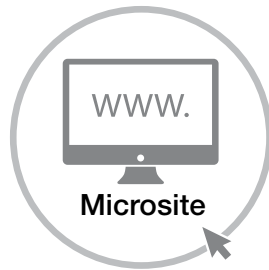

Your Trusted Partner in Automation

Moxa is a leading provider of edge connectivity, industrial computing, and network infrastructure solutions for enabling connectivity for the Industrial Internet of Things. With over 25 years of industry experience, Moxa has connected more than 40 million devices worldwide and has a distribution and service network that reaches customers in more than 70 countries. Moxa delivers lasting business value by empowering industry with reliable networks and sincere service for industrial communications infrastructures.

© 2016 Moxa Inc., All rights reserved.

The MOXA logo is a registered trademark of Moxa Inc. All other logos appearing in this document are the intellectual property of the respective company, product, or organization associated with the

MOXA[®]
Reliable Networks ▲ Sincere Service